

TOMAHAWK

TFS6H
GREEN CONCRETE SAW

Instruction Manual

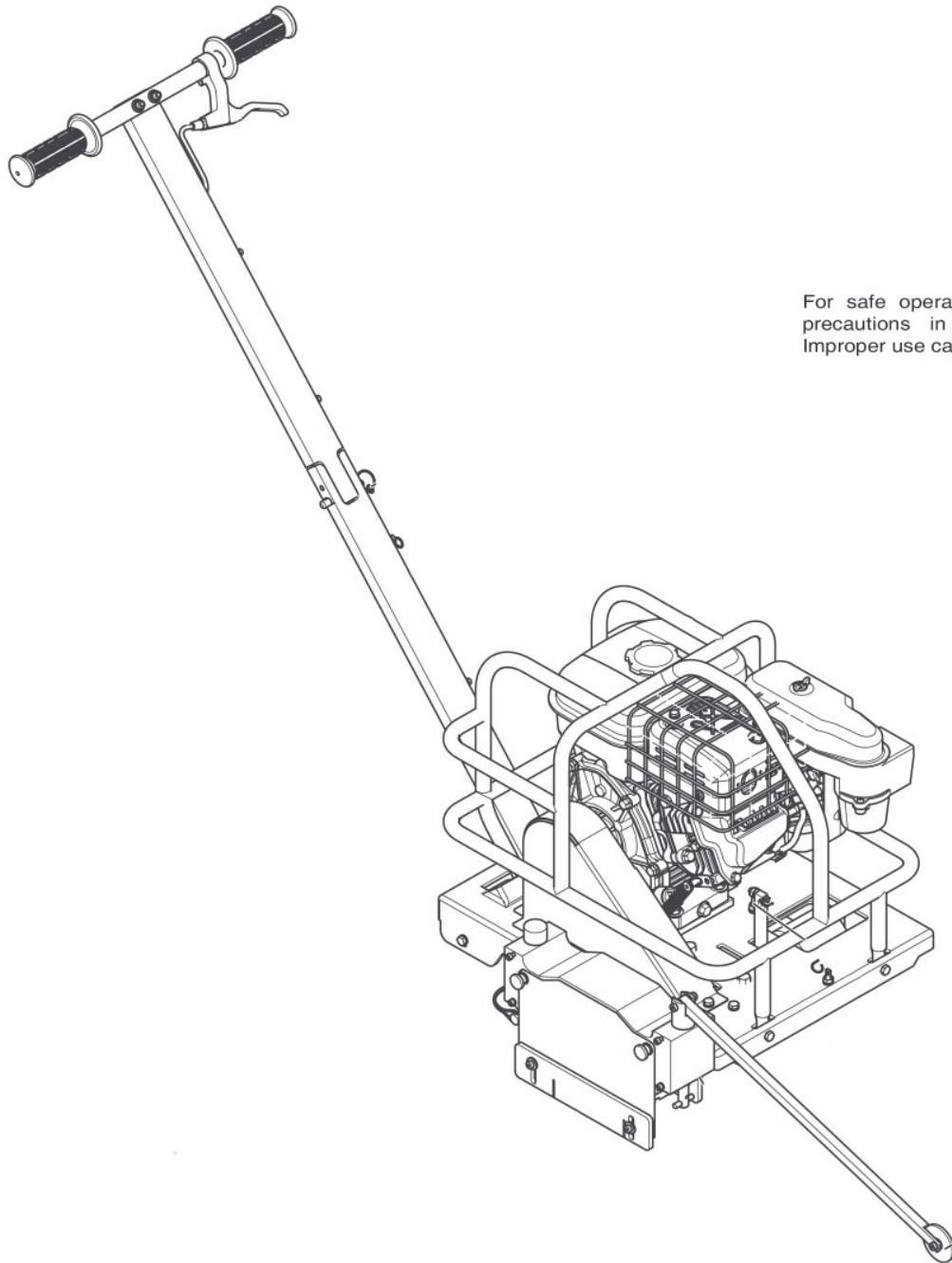

For safe operation follow all safety precautions in Instruction Manual. Improper use can cause serious injury.

KEY TO SYMBOLS

Symbols on the machine

WARNING! The machine can be a dangerous tool if used incorrectly or carelessly, which can cause serious or fatal injury to the operator or others.



Please read the operator's manual carefully and make sure you understand the instructions before using the machine.



Keep all parts of your body away from hot surfaces.



Engine exhaust fumes contain carbon monoxide, which can cause carbon monoxide poisoning. For this reason you should not start or run the machine indoors, or anywhere that is poorly ventilated.



Always stop the engine and let it cool for a few minutes before refuelling.



Fire, open flame and smoking are prohibited.



On (Run)



Off (Stop)



Engine oil



Too low oil level. Fill with engine oil to the correct level.

This product is in accordance with applicable EC directives.



Noise emission to the environment according to the European Community's Directive. The machine's emission is specified in the Technical data chapter and on the label.



Environmental marking. Symbols on the product or its packaging indicate that this product cannot be handled as domestic waste. It must instead be submitted to an appropriate recycling station for the recovery of electrical and electronic equipment.



By ensuring that this product is taken care of correctly, you can help to counteract the potential negative impact on the environment and people that can otherwise result through the incorrect waste management of this product.

For more detailed information about recycling this product, contact your municipality, your domestic waste service or the shop from where you purchased the product.

Other symbols/decals on the machine refer to special certification requirements for certain markets.

Explanation of warning levels

The warnings are graded in three levels.

WARNING!



WARNING! Used if there is a risk of serious injury or death for the operator or damage to the surroundings if the instructions in the manual are not followed.

CAUTION!



CAUTION! Used if there is a risk of injury to the operator or damage to the surroundings if the instructions in the manual are not followed.

NOTICE!



NOTICE! Used if there is a risk of damage to materials or the machine if the instructions in the manual are not followed.

CONTENTS

Contents

KEY TO SYMBOLS

Symbols on the machine	2
Explanation of warning levels	2

CONTENTS

Contents	3
----------------	---

PRESENTATION

Dear Customer,	4
Design and features	4
Features	4

PRESENTATION

What is what on the machine?	5
------------------------------------	---

MACHINE'S SAFETY EQUIPMENT

General	6
---------------	---

BLADES

General	8
Excel Series blades	8
Transport and storage	8

ASSEMBLING AND ADJUSTMENTS

General	9
Unpacking	9
Fit the blade	9
Pre operational checks	10
Transport	10

FUEL HANDLING

General	11
Fuel	11
Fueling	11
Disposal	11
Transport and storage	11

OPERATING

Protective equipment	12
General safety precautions	12
Work safety	13
Transport and storage	14
Starting and stopping	14

MAINTENANCE

General	16
Maintenance schedule	16
Cleaning	16
Check	17
Change	18
Additional engine information	18

TROUBLESHOOTING

Troubleshooting schedule	19
--------------------------------	----

TECHNICAL DATA

Technical data	20
EC Declaration of Conformity	21

PRESENTATION

Dear Customer,

Thank you for choosing a Tomahawk Power product!

It is our wish that you will be satisfied with your product and that it will be your companion for a long time. A purchase of one of our products gives you access to professional help with repairs and services. If the retailer who sells your machine is not one of our authorised dealers, ask him for the address of your nearest service workshop.

This operator's manual is a valuable document. Make sure it is always at hand at the work place. By following its content (operating, service, maintenance etc.) the life span and the second-hand value of the machine can be extended. If you will sell this machine, make sure that the buyer will get the operator's manual.

More than 300 years of innovation

Based in San Diego, CA, Tomahawk Power LLC is a business that dedicates itself to providing customers with superior equipment for the construction, rental, and agricultural industries. We manufacture specialized diesel generators and light construction equipment to fit in all types of extreme environments.

Owner responsibility

It is the owner's/employer's responsibility that the operator has sufficient knowledge about how to use the machine safely. Supervisors and operators must have read and understood the Operator's Manual. They must be aware of:

- The machine's safety instructions.
- The machine's range of applications and limitations.
- How the machine is to be used and maintained.

National legislation could regulate the use of this machine. Find out what legislation is applicable in the place where you work before you start using the machine.

The manufacturer's reservation

Subsequent to publishing this manual Tomahawk Power may issue additional information for safe operation of this product. It is the owner's obligation to keep up with the safest methods of operation.

Tomahawk Power AB has a policy of continuous product development and therefore reserves the right to modify the design and appearance of products without prior notice.

For customer information and assistance, contact us at our website: www.Tomahawk Power.com

Design and features

Values such as high performance, reliability, innovative technology, advanced technical solutions and environmental considerations distinguish Husqvarna's products. Safe operation of this product requires the operator to read this manual carefully. Ask your dealer or Tomahawk Power should you need more information.

Some of the unique features of your product are described below.

Features

Values such as high performance, reliability, innovative technology, advanced technical solutions and environmental considerations distinguish Husqvarna's products.

Some of the unique features of your product are described below.

Low noise and low dust blade block enclosure

The patented low noise and low dust blade block and skid plate technology in conjunction with Tomahawk Power Excel blades allows for Ultra Early Entry sawing the same day while minimizing chipping and spalling.

Low vibration Robin engine

Low vibration 3.2 kW Robin engine with cyclone air filter and an oil alert system that will stop the engine if the oil level is low. Easy to pull-start.

Additional features

- Manual push style with manual controls for all functions.
- Mechanical blade depth control.
- Non-marking and non-stick polyurethane wheels.
- High strength single piece frame.
- Folding handle.
- Distinctive roll cage style framework.
- Patented safety arbor.
- Retractable front guide system.

PRESENTATION

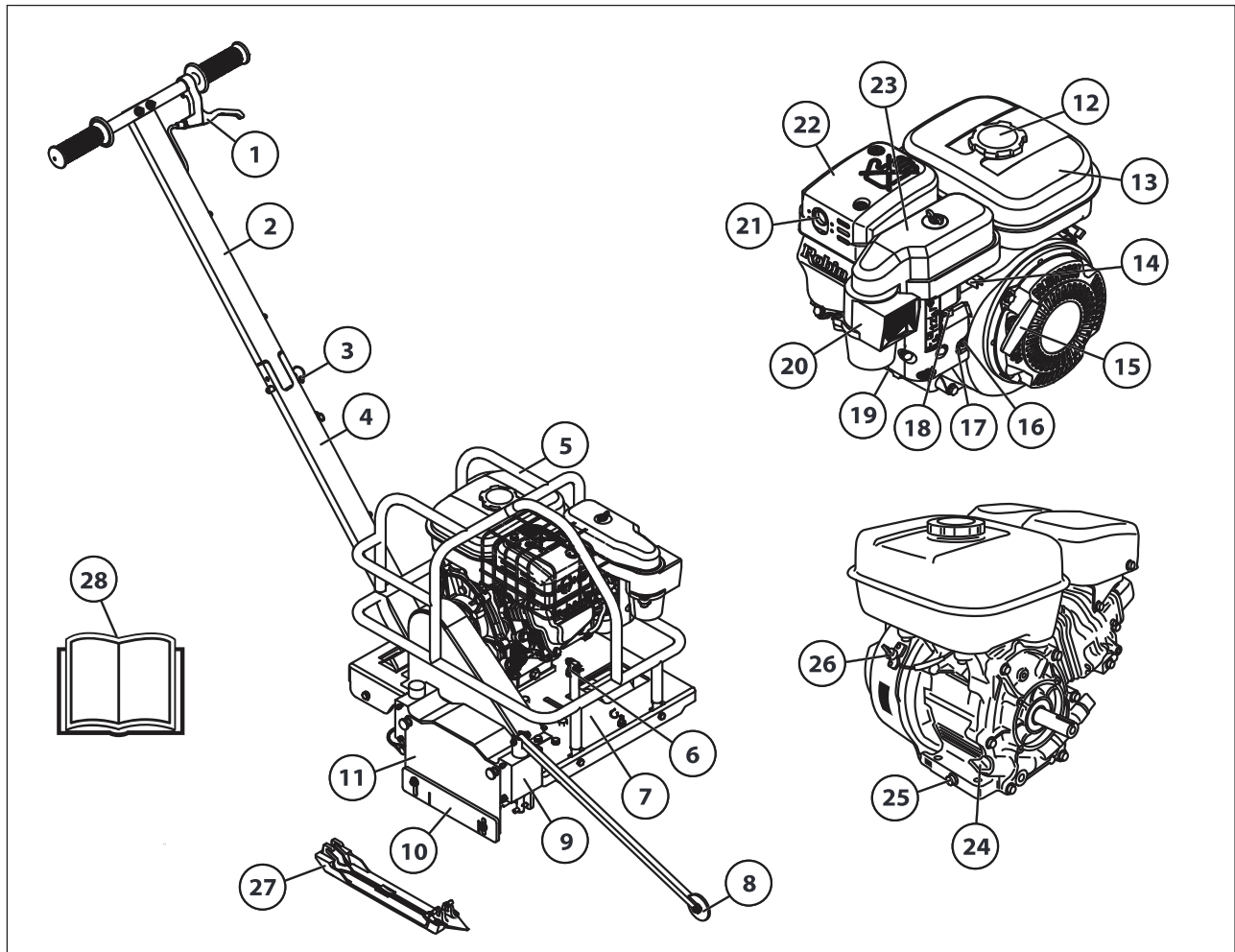

What is what on the machine?

- | | | | |
|----|-----------------------|----|---------------------------------------|
| 1 | Blade release lever | 15 | Starter handle |
| 2 | Upper handle | 16 | Fuel valve |
| 3 | Locking pin, handle | 17 | Fuel cup |
| 4 | Lower handle | 18 | Choke control |
| 5 | Roll cage | 19 | Carburettor |
| 6 | Depth stop adjustment | 20 | Cyclonic pre-cleaner |
| 7 | Saw frame | 21 | Exhaust outlet |
| 8 | Front guide | 22 | Muffler cover |
| 9 | Blade block | 23 | Muffler cover |
| 10 | Lexan cover | 24 | Dipstick/oil filler |
| 11 | Blade block guard | 25 | Drain plug |
| 12 | Fuel tank filler cap | 26 | ON/OFF switch |
| 13 | Fuel tank | 27 | Skid plate (Not included in the box). |
| 14 | Throttle trigger | 28 | Operator's manual |

MACHINE'S SAFETY EQUIPMENT

General



WARNING! Never use a machine that has faulty safety equipment! If your machine fails any checks contact your service agent to get it repaired. The engine should be switched off during operations described in this chapter unless otherwise stated.

This section describes the machine's safety equipment, its purpose, and how checks and maintenance should be carried out to ensure that it operates correctly.

ON/OFF switch

The ON/OFF switch is used to turn the engine on and off.

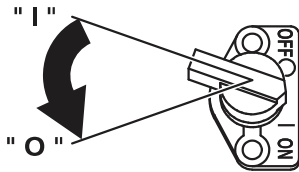

Checking the ON/OFF switch

- Turn the switch to the 'ON' ('1' position) to start the engine. The blade starts to rotate when the engine is turned on.
- Turn the switch to the 'OFF' ('0' position). Check that the engine stops.

Blade block guard

The blade block protects the operator from the rotating blade and controls dust.

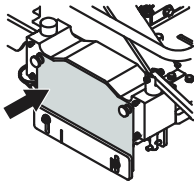

Checking the blade block guard

- Check that the guard is undamaged and not cracked. Replace the guard if it has been exposed to impact or is cracked.
- A damaged blade block assembly must be replaced to protect the operator.
- Always check that the guard is correctly fitted before starting the machine.

Lexan cover

- The lexan cover primarily controls dust, but also aids to deflect particle ejection.

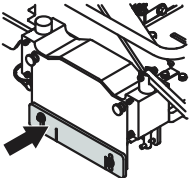

Checking the lexan cover

- Check that the guard is undamaged and not cracked. Replace the guard if it has been exposed to impact or is cracked.
- Always check that the guard is correctly fitted before starting the machine.
- Ensure the lexan cover move freely up and down.

Roll cage

The roll cage protects the equipment/engine and operator from damage.

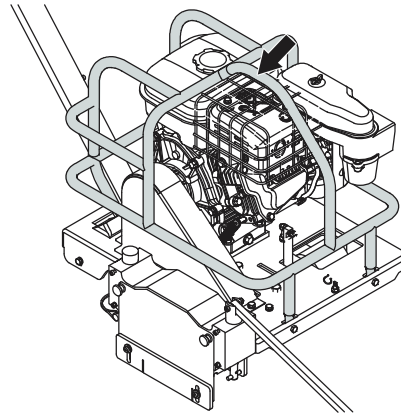

Checking the roll cage

- Check that the guard is undamaged and not cracked. Replace the guard if it has been exposed to impact or is cracked.
- Always check that the guard is correctly fitted before starting the machine.

Belt guard

The belt guard protects the operator from rotating sheaves and belt.

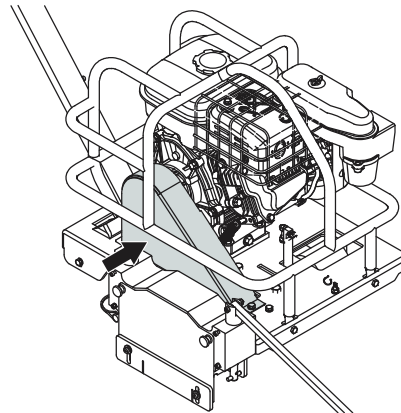

Checking the belt guard

- Check that the guard is undamaged and not cracked. Replace the guard if it has been exposed to impact or is cracked.
- Always check that the guard is correctly fitted before starting the machine.

MACHINE'S SAFETY EQUIPMENT

Sheave guard

The sheave guard protects the operator from rotating bladeshaft sheave.

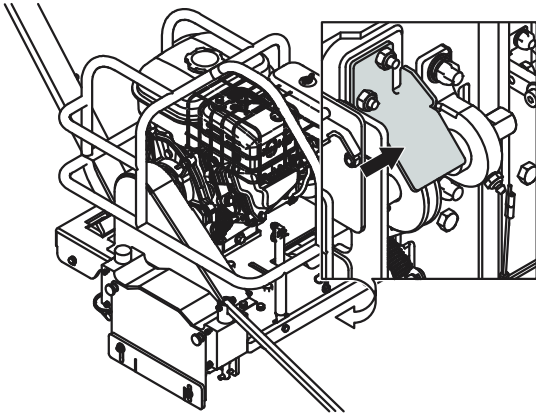

Checking the sheave guard

- Check that the guard is undamaged and not cracked. Replace the guard if it has been exposed to impact or is cracked.
- Always check that the guard is correctly fitted before starting the machine.

Muffler guard

The muffler guard protects the operator from getting into contact with the hot muffler.

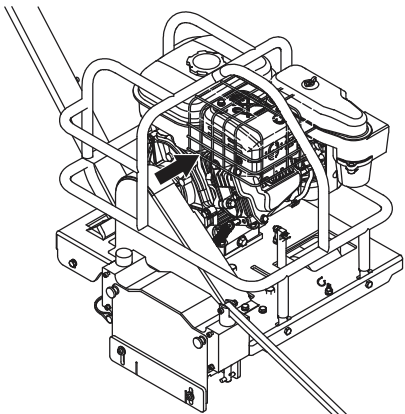

Checking the muffler guard

- Check that the guard is undamaged and not cracked. Replace the guard if it has been exposed to impact or is cracked.
- Always check that the guard is correctly fitted before starting the machine.

BLADES

General



CAUTION! Inspect the blade for damage, cracks, loss of segments, warping, overheating, excessive wear or a damaged tri-arbor hole. If the blade shows any of these problems, discard the blade.

Make sure the blade is marked with a maximum operating speed greater than 4450 rpm.

Use only Tomahawk Power Excel Series blades or blades marked with a maximum operating speed greater than 4450 rpm.

Excel Series blades



CAUTION! Tomahawk Power Excel Series diamond blades are designed to only cut green concrete. Cutting any other material may result in blade failure or a dangerous condition.

The Excel Series are designed specifically for the Soff-Cut Ultra Early Entry dry cutting system of green concrete.

These specialty blades are designed to increase speed and life while cutting a wide range of aggregates.

Choose the correct blade for your application. If you are uncertain of what blade to use contact your local service dealer.

Excel 1000 purple	XL6-1000	Ultra hard aggregate and non abrasive sand.
Excel 2000 green	XL6-2000	Hard to ultra hard aggregate and non abrasive sand.
Excel 3000 red	XL6-3000	Hard aggregate, medium abrasive sand.
Excel 4000 orange	XL6-4000	Medium hard aggregate, medium abrasive sand.
Excel 5000 yellow	XL6-5000	Medium hard to soft aggregate, abrasive sand
Excel 6000 black	XL6-6000	Soft aggregate, highly abrasive sand.

Transport and storage

- Remove the blade before transportation or storage of the machine.
- Store the blade in a dry place.
- Inspect new blades for transport or storage damage.

ASSEMBLING AND ADJUSTMENTS

General



WARNING! The engine should be switched off during operations described in this chapter unless otherwise stated. Remove the ignition cable from the spark plug to prevent accidental engine starting.

Unpacking

- Remove the saw from the package. The saw should be lifted from the center handle on the roll cage.
- Discard or recycle the packing material per your regional laws.

No diamond cutting blade or skid is included with the saw. Purchase the appropriate blade and skid plate from your local Tomahawk Power Construction Product dealer.

Fit the blade



CAUTION! Inspect the blade for damage, cracks, loss of segments, warping, overheating, excessive wear or a damaged tri-arbor hole. If the blade shows any of these problems, discard the blade.

Make sure the blade is marked with a maximum operating speed greater than 4450 rpm.

Inspect blade flanges for damage, excessive wear and cleanliness. The blade should fit snugly on clean, undamaged, tri-arbor shaft.

- Fold the handle to its full upright position.
- Insert the locking pin.

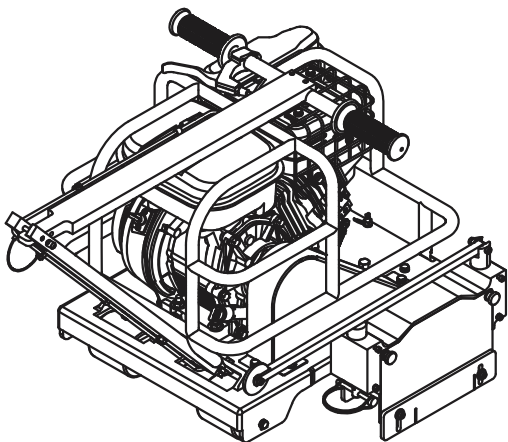

- Raise the blade by pushing down on the handle bar with both hands to the full and locked position.

- Remove the blade block guard.

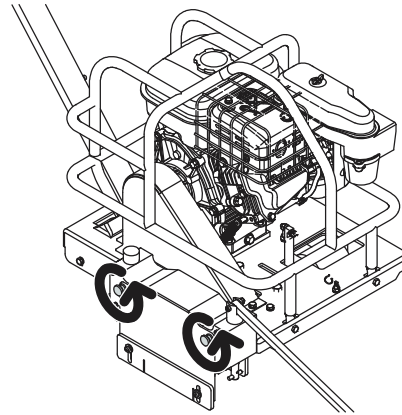

- Insert one of the two wrenches supplied, in the slot at the front of the engine and one on the blade shaft bolt.

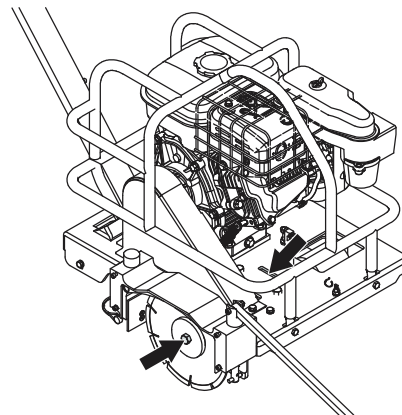

- Rotate the blade shaft counter-clockwise with wrench on the blade shaft bolt until the second wrench engages the flats on the other end of the shaft.
- Remove the blade shaft bolt by continuing to turn the bolt counter-clockwise.
- Remove the outer blade flange.
- Discard the old skid plate.

NOTICE! The patented skid plate is the most important part of the Soff-Cut Ultra Early Entry system. If it is bent, twisted or damaged, spalling and raveling of a cut may result. Store skid plates carefully and install them properly. Install a new skid plate with each new blade. Never re-use skid plates.

- Thoroughly clean the concrete from the shaft, blade block and blade block guard.
- Mount the clean blade on the blade shaft.

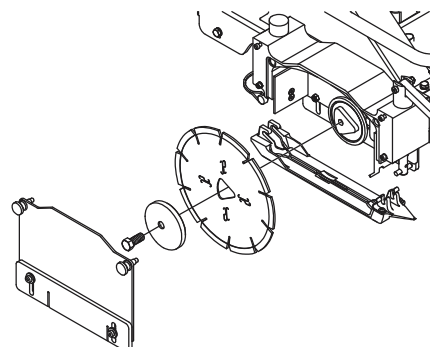

ASSEMBLING AND ADJUSTMENTS

- Mount the outer blade flange. Tighten the bolt firmly.
- Install a new skid plate.

Hook the front of the skid plate on the front blade block shaft pin.

Connect the rear blade block shaft and the rear of the skid plate by installing the locking pin.

- Mount the blade block guard. Tighten until fully seated against the blade block.
- Lift the front and rear of the skid plate to ensure the blade slides freely through the skid plate.
- Ensure the lexan cover move freely up and down.

Pre operational checks

The engine is delivered without oil. Fill with engine oil to the correct level. Refer to Technical Data for recommendations on which oil type to use.

Transport

- Remove the locking pin.
- Fold the handle forward.
- Fold the guide arm back.
- The saw should be lifted from the center handle on the roll cage.

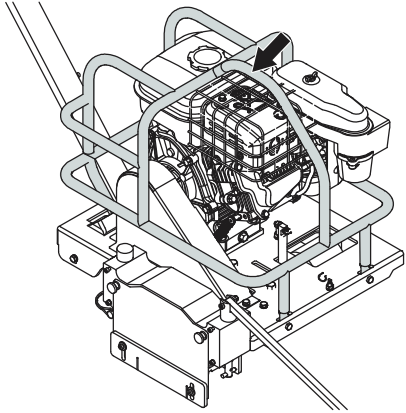

FUEL HANDLING

General



WARNING! Running an engine in a confined or badly ventilated area can result in death due to asphyxiation or carbon monoxide poisoning. Use fans to ensure proper air circulation when working in trenches or ditches deeper than one meter.

Fuel and fuel fumes are highly flammable and can cause serious injury when inhaled or allowed to come in contact with the skin. For this reason observe caution when handling fuel and make sure there is adequate ventilation.

The exhaust fumes from the engine are hot and may contain sparks which can start a fire. Never start the machine indoors or near combustible material!

Do not smoke and do not place any hot objects in the vicinity of fuel.

Fuel

Use unleaded gasoline with an octane rating of 87 or higher.

Unleaded gasoline with more than 10% ethanol should not be used. It may cause starting and/or performance problems. It may also damage metal, rubber, and plastic parts of the fuel system, as well as posing a fire hazard.

Do not use gasoline containing methanol.

Do not use fuel that is older than 30 days. Old fuel can cause running problems as well as fuel system damage.

Fueling



WARNING! Always stop the engine and let it cool for a few minutes before refuelling. Refuel in a well ventilated area. Never fuel the machine indoors.

When refuelling, open the fuel cap slowly so that any excess pressure is released gently. Never overfill the fuel tank.

Clean the area around the fuel cap.

Tighten the fuel cap carefully after refuelling. Check for fuel leaks.

Negligence may lead to the start of a fire.

Remove the machine from the vehicle and refuel it on the ground. If this is not possible, refuel the equipment with a portable container, rather than from a petrol dispenser nozzle.

Use only approved gasoline containers.

Never fill containers inside a vehicle. Always place the container on the ground away from your vehicle when filling.

Keep the nozzle in contact with the rim of the fuel tank or container opening at all times until fuelling is complete. Do not use a nozzle lock-open device.

Never start the machine:

- If you have spilled fuel or engine oil on the machine. Wipe off the spill and allow the remaining fuel to evaporate.
- If you have spilled fuel on yourself or your clothes, change your clothes. Wash any part of your body that has come in contact with fuel. Use soap and water.
- If the machine is leaking fuel. Check regularly for leaks from the fuel cap and fuel lines.

Disposal

Used engine oil, antifreeze etc. is a health hazard and must not be disposed of on the ground or in nature; it should always be disposed of at a workshop or appropriate disposal location.

Transport and storage

Store and transport the machine and fuel so that there is no risk of any leakage or fumes coming into contact with sparks or open flames, for example, from electrical machinery, electric motors, electrical relays/switches or boilers.

When storing and transporting fuel always use approved containers intended for this purpose.

Long-term storage

When storing the machine for long periods the fuel tank must be emptied. Contact your local petrol station to find out where to dispose of excess fuel.

OPERATING

Protective equipment

General

- Do not use the machine unless you are able to call for help in the event of an accident.

Personal protective equipment

You must use approved personal protective equipment whenever you use the machine. Personal protective equipment cannot eliminate the risk of injury but it will reduce the degree of injury if an accident does happen. Ask your dealer for help in choosing the right equipment.



WARNING! The use of products such as cutters, grinders, drills, that sand or form material can generate dust and vapours which may contain hazardous chemicals. Check the nature of the material you intend to process and use an appropriate breathing mask.

Long-term exposure to noise can result in permanent hearing impairment. So always use approved hearing protection. Listen out for warning signals or shouts when you are wearing hearing protection. Always remove your hearing protection as soon as the engine stops.

Always wear:

- Approved protective helmet
- Hearing protection
- Approved eye protection.
- Breathing mask
- Heavy-duty, firm grip gloves.
- Tight-fitting, heavy-duty and comfortable clothing that permits full freedom of movement.
- Boots with steel toe-caps and non-slip sole.
- Wear rubber work gloves to avoid contact with wet concrete which can cause serious skin irritation.

Be careful as clothing, long hair, and jewellery can get caught in moving parts.

Other protective equipment



CAUTION! Sparks may appear and start a fire when you work with the machine. Always keep fire fighting equipment handy.

- Fire Extinguisher
- Always have a first aid kit nearby.

General safety precautions



WARNING! Read all safety warnings and all instructions. Failure to follow the warnings and instructions may result in electric shock, fire and/or serious injury.

This section describes basic safety directions for using the machine. This information is never a substitute for professional skills and experience.

- Please read the operator's manual carefully and make sure you understand the instructions before using the machine.
- Keep in mind that it is you, the operator that is responsible for not exposing people or their property to accidents or hazards.
- All operators shall be trained in the use of the machine. The owner is responsible for ensuring that the operators receive training.
- The machine must be kept clean. Signs and stickers must be fully legible.



WARNING! The machine can be a dangerous tool if used incorrectly or carelessly, which can cause serious or fatal injury to the operator or others.

Never allow children or other persons not trained in the use of the machine to use or service it.

Never allow anyone else to use the machine without first ensuring that they have read and understood the contents of the operator's manual.

Never use the machine if you are fatigued, while under the influence of alcohol or drugs, medication or anything that could affect your vision, alertness, coordination or judgement.



WARNING! Unauthorized modifications and/or accessories may lead to serious injury or death to the user or others. Under no circumstances may the design of the machine be modified without the permission of the manufacturer.

Do not modify this product or use it if it appears to have been modified by others.

Never use a machine that is faulty. Carry out the safety checks, maintenance and service instructions described in this manual. Some maintenance and service measures must be carried out by trained and qualified specialists. See instructions under the Maintenance heading.

Always use genuine accessories.

OPERATING



WARNING! This machine produces an electromagnetic field during operation. This field may under some circumstances interfere with active or passive medical implants. To reduce the risk of serious or fatal injury, we recommend persons with medical implants to consult their physician and the medical implant manufacturer before operating this machine.

Always use common sense

It is not possible to cover every conceivable situation you can face. Always exercise care and use your common sense. If you get into a situation where you feel unsafe, stop and seek expert advice. Contact your dealer, service agent or an experienced user. Do not attempt any task that you feel unsure of!

Work safety

Work area safety

- **Keep work area clean and well lit.** Cluttered or dark areas invite accidents.
- Define and cordon off the risk area. Keep people and animals well away from the risk area.
- People and animals can distract you causing you to lose control of the machine. For this reason, always remain concentrated and focused on the task.
- Do not use the machine in bad weather, such as dense fog, heavy rain, strong wind, intense cold, etc. Working in bad weather is tiring and can lead to dangerous conditions, e.g. slippery surfaces.
- Never start to work with the machine before the working area is clear and you have a firm foothold.

Personal safety

- Never use the machine if you are fatigued, while under the influence of alcohol or drugs, medication or anything that could affect your vision, alertness, coordination or judgement.
- Prevent unintentional starting. Ensure the switch is in the OFF-position.
- Check that no tools or other objects have been left lying on the machine.
- Never allow anyone else to use the machine without proper training.
- Always shut off the machine during longer work breaks.
- Never work alone, always ensure there is another person close at hand.
- Learn how to use the machine and its controls safely and learn to how to stop quickly. Also learn to recognize the safety decals.
- Do not overreach. Keep proper footing and balance at all times.

Use and care

- Experience is very important when running the machine. A skilled worker is highly recommended.
- Always perform daily maintenance before starting the engine. See instructions in the section "Maintenance".
- The machine is intended for use in industrial applications by experienced operators.
- Only operate the saw from behind the machine with both hands on the handle.
- Use caution when loading, unloading and when manoeuvring the machine on ramps.
- Do not use the machine as vehicle for transporting personnel or equipment.
- Never stand on the machine.
- Do not overload the machine. Overloading can damage the machine.
- Keep tools sharp and clean in order to enable safer work.
- Keep all parts in good working order and ensure that all fixtures are properly tightened.
- Never leave the machine unsupervised with the motor running.
- Make sure the blade does not make contact with the ground or any other surface when manoeuvring the saw.
- Avoid getting in direct line with the blade or contacting the blade while it is rotating.

Basic working techniques

Sawing contraction joint

As concrete hydrates or cures and begins to set, it develops internal stresses which may cause random cracks.

Random cracks cast doubt on the quality and workmanship of the concrete. Contraction joints are cut in concrete to relieve these stresses before they seek their own relief in the form of random crack.

The Soff-Cut Ultra Early Entry system controls random cracking through the early timing of a saw cut at predetermined locations to create weakened planes in the concrete that subsequently crack at the bottom of the cut to relieve stress.

Tomahawk Power sawed contraction joints should be a minimum of 1/8th the concrete depth and a minimum of 25 mm (1") deep.

Contraction joints should be sawn as soon as the concrete will support the weight of the saw and the operator without marking or damaging the concrete.

There are many possibilities for joint layout. Joint layout should be provided, the saw contractor should submit a detailed joint layout for approval prior to cutting.

Several factors affect joint spacing including:

- Concrete thickness.
- Type, amount and location of reinforcement.
- Shrinkage potential of concrete-cement (type, quantity), aggregate (size, quantity, quality), water to cement ratio, admixtures, concrete temperature.

OPERATING

- Base friction.
- Slab restraints.
- Layout of foundations, racks, pits, equipment pad, trenches, etc.
- Environmental factors - temperature, wind, humidity.
- Methods and quality of concrete curing.

Generally, contraction joint patterns should divide slabs into approximate square panels per the recommended spacing shown.

Recommended contraction joint spacing

Concrete thickness, mm (in.)	Maximum spacing, m (ft.)
90 (3.5)	2,4 (8)
100, 114 (4, 4.5)	3,0 (10)
125, 140 (5, 5.5)	3,6 (12)
150 (6) or greater	4,5 (15)

At all intersecting cross cuts, install Tomahawk Power joint protectors at each joint to prevent joint damage. Install an additional joint protector where the right wheel will cross the joint to prevent concrete damage.

Maximizing the Soff-Cut system

'The timing of concrete operations - especially finishing and jointing - is critical...Failure to address this issue can contribute to undesirable characteristics in the wearing surface as cracking...' (Extract from the foreword of the American Concrete Institute (ACI) 302.1 R-96.)

The patented Soff-Cut Ultra Early Entry system has revolutionized the method used to control random cracking.

In order for an operator to do a satisfactory job using the Soff-Cut system, the following criteria must be met:

- A Soff-Cut Ultra Early Entry dry up-cut saw.
- A Tomahawk Power Excel Series dry-cutting diamond blade.
- A Tomahawk Power anti-ravel skid plate installed with every new diamond blade.
- An operator skilled in using the Soff-Cut Ultra Early Entry cutting system.

Without this, joints can not be cut clearly enough to control random cracking before it starts, which is what the building owner is paying for.

The ACI Spec 302.1R-96 says it best:

'Early-entry dry-cut saws use diamond-impregnated blades and a skid plate that helps prevent spalling. Timely changing of skid plates is necessary to effectively control spalling. It is best to change skid plates in accordance with manufacturer's recommendations...The goal of saw-cutting is to create a weakened plane as soon as the joint can be cut...The timing of the early-entry process allows joints to be in place prior to development of significant tensile stress in the concrete...'

The Portland Cement Association (PCA) engineering bulletin, Concrete Floors on the ground, also states:

'Proper jointing can eliminate unsightly random cracks. Aspects of jointing that lead to a good job are choosing the correct type of joint for each location, establishing a good joint pattern and layout, and installing the joint at the correct time...'

Timing of joint sawing is critical...Lightweight, high-speed, early-cut saws have been developed to permit the joint sawing very soon after floor finishing, sometimes within 0 to 2 hours...if the cut is sawn within a few hours after the final finishing, random cracking can be controlled...'

Tomahawk Power has the only Ultra Early Entry dry-cutting system (Soff-Cut) which controls random cracking through the early timing of the cut. With the patented Soff-Cut method, control joints are usually cut within 2 hours after the finishing process.

Joint cutting should begin as soon as the concrete will support the weight of the saw and the operator at each joint location and before final set.

If the joints are not being cut within this time frame then the Soff-Cut Ultra Early Entry method is not being followed.

Transport and storage



CAUTION! The saw should be lifted from the center handle on the roll cage.

- If two people are lifting the saw, use the roll cage bar on each side of the saw and lift with two hands.
- Always store the saw in a completely lowered position and secured from moving.
- Close the fuel valve.
- Secure the equipment during transportation in order to avoid transport damage and accidents.
- Store the equipment in a lockable area so that it is out of reach of children and unauthorized persons.
- Remove the blade before transportation or storage of the machine.
- Store the machine and its equipment in a dry and frost proof place.

Starting and stopping

Before starting



WARNING! Please read the operator's manual carefully and make sure you understand the instructions before using the machine.

Wear personal protective equipment. See instructions under the "Personal protective equipment" heading.

Make sure no unauthorised persons are in the working area, otherwise there is a risk of serious personal injury.

Check that the guards are mounted correctly and do not show any signs of damage. See instructions in the section "Machine's safety equipment" and "Assembly and settings".

- Perform daily maintenance. See instructions in the section "Maintenance".
- Check that the handle is in full upright position and pinned.
- Check that the front guide is rotated to the forward position.

OPERATING

Starting

Start the engine

- Open the fuel valve.

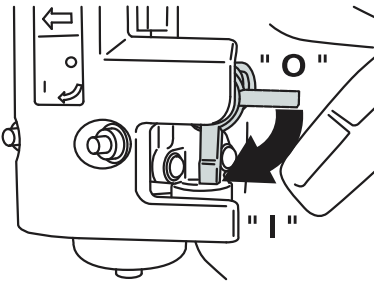

- Raise the blade by pushing down on the handle bar with both hands to the full and locked position.
- Turn the switch to the 'ON' ('I' position) to start the engine. The blade starts to rotate when the engine is turned on.

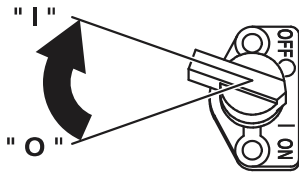

- Move the speed lever 1/3 of the way to the open position.

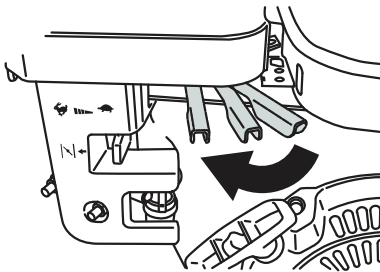

- Close the engine choke lever.

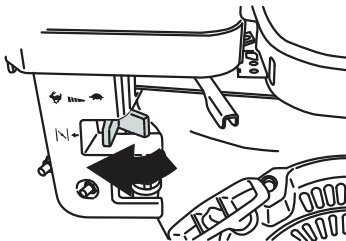

The closed choke position enriches the fuel mixture for starting a cold engine.

The open choke position provides the correct fuel mixture for operation after the engine starts and for restarting a warm engine.

- Pull the starter handle.
- After the engine starts, slowly open the choke. Allow the engine to warm for a few minutes.

Start cutting

- Open the engine throttle lever to full open position for maximum engine speed.
- Line up the saw with the cut line using the white wheel on the front guide and the triangle pointer on the back of the blade block.
- Push down on the saw handle and pull the blade release lever to lower the blade in the concrete slowly.
- Push the saw forward to cut keeping the front guide wheel in the cut line.
- Push the saw at about half speed for the first 50 feet to allow the blade to develop good diamond exposure.
- Increase the forward speed of the saw until the blade and engine are working at maximum efficiency. Do not force the saw.
- When approaching a wall, raise the front guide and use the triangle guide at the back of the blade block to cut the last few feet.
- Do not hit the blade block assembly against any object. Damage may result.

Stopping

- Raise the blade by pushing down on the handle bar with both hands to the full and locked position.
- Move the engine throttle lever to the full closed position.
- Turn the switch to the 'OFF' ('O' position).
- Close the fuel valve.
- Clean the machine.

MAINTENANCE

General



WARNING! The user must only carry out the maintenance and service work described in this Operator's Manual. More extensive work must be carried out by an authorized service workshop.

The engine should be switched off during operations described in this chapter unless otherwise stated.

Wear personal protective equipment. See instructions under the "Personal protective equipment" heading.

The life span of the machine can be reduced and the risk of accidents can increase if machine maintenance is not carried out correctly and if service and/or repairs are not carried out professionally. If you need further information please contact your nearest service workshop.

Let your Tomahawk Power dealer regularly check the machine and make essential adjustments and repairs.

Maintenance schedule

In the maintenance schedule you can see which parts of your machine that require maintenance, and with which intervals it should take place. The intervals are calculated based on daily use of the machine, and may differ depending on the rate of usage.

	Daily maintenance	Weekly maintenance/40 hours	Monthly maintenance/200 hours
Cleaning	External cleaning	Air cleaner	Fuel cup
		Spark plug	
Check	General inspection	Drive belt	Spark plug and electrode gap
	Skid plate		
	Lexan cover*		
	Blade block guard*		
	Blade**		
	Fuel level***		
	Oil level		
Change		Oil (After the first 20 h then every 100 h)	Air cleaner element
Greasing		Blade shaft bearings	

*See instructions in the section "Machine's safety equipment".

** See instructions in the section "Blades" and "Assembly and settings".

***See instructions in the section "Fuel handling".

Cleaning

External cleaning

- Clean the machine daily by rinsing it with clean water after the work is finished. Keep the handles clean and dry.
- Clean the blade block of any excess concrete build up after each use. Use a heavy-duty hand-held brush or a large paint brush.
- If you have spilled fuel or engine oil on the machine. Wipe off the spill and allow the remaining fuel to evaporate.
- Keep all openings and slots on the saw clean open so air flows freely through the engine compartment to ensure proper cooling.

MAINTENANCE

Air cleaner

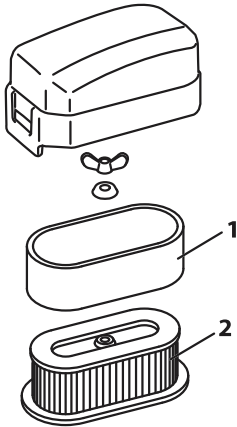

- Wash the urethane foam filter (1) with detergent. Allow the filter to dry.
- Clean the paper element (2) by tapping gently to remove dirt and blow off dust.

Spark plug

- Ensure that the spark plug cap and ignition lead are undamaged to avoid the risk of electric shock.
- Clean off carbon deposits on the spark plug electrode using a plug cleaner or wire brush.

Fuel cup

- Inspect fuel cup for water and dirt.
- To remove water and dirt, close the fuel tap and remove the fuel cup.
- After removing dirt and water, wash the fuel cup with kerosene or gasoline.
- Reinstall securely to prevent leakage.

Check

General inspection

- Check that nuts and screws are tight.
- Check for fuel and oil leakage.

Skid plate

- Check for damage and excessive wear in the blade slot.
- Check for burrs on the concrete surface side and twisting.
- Install a new skid plate with each new blade. Never re-use skid plates.
- Lift the front and rear of the skid plate to ensure the blade slides freely through the skid plate.

Oil level

- Turn off the engine.
- Lower the machine and make sure the engine is in level.
- Remove the oil cap and wipe the dipstick clean.

- Check the oil level. Do not screw the oil dipstick into the oil filler neck to check the oil level.

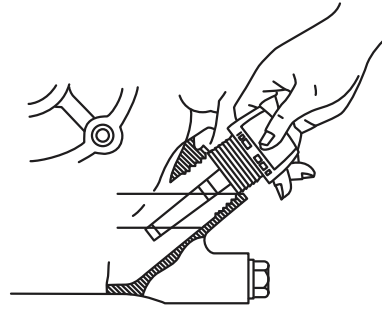

- If the oil level is low, fill using engine oil up to the upper level on the dipstick. See instructions in section "Technical data" for oil specification.
- Screw on the oil filler cap.

Drive belt

- Check that drive belt is not damaged and is not visibly defective.
- The belt tension is controlled by belt tensioner and does not require adjustment.
- Inspect the belt tensioner for free movement up and down.
- Ensure the belt tensioner bearings roll freely.

Blade shaft bearings

- Lubricate the blade shaft bearings with 3 pumps of Lithium 12 based grease.

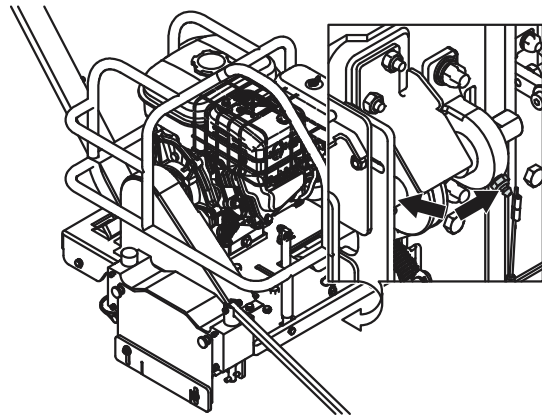

Spark plug and electrode gap

- See cleaning instructions under the heading "Cleaning".
- Check electrode gap. The gap should be 0.6 mm to 0.7 mm (0.02 inch.-0.03 inch).

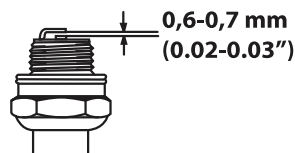

- Adjust the gap, if necessary, by carefully bending the side electrode.

MAINTENANCE

Change

Oil

Change oil after the first 20 hours of use thereafter every 100 hours.

Change the engine oil while the engine is hot.

- Turn off the engine.
- Place a pan under the drain and remove the plug.

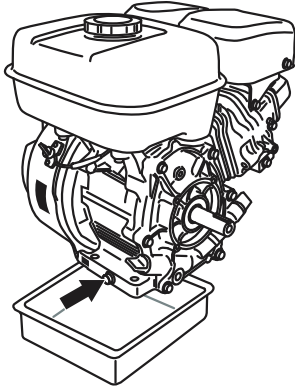

- Let the oil run out into the container.
- Put the plug back and fill with new oil.
- When full, the oil level should be at the high level mark on the dipstick.

Oil sensor

The engine is equipped with an oil alert system that will stop the engine if the oil level is low.

The engine cannot be started unless the level is raised above the prescribed limit.

Disposal

Used engine oil, antifreeze etc. is a health hazard and must not be disposed of on the ground or in nature; it should always be disposed of at a workshop or appropriate disposal location.

Air cleaner element

See cleaning instructions under the heading "Cleaning".

- Replace the paper element monthly or earlier if necessary.

Additional engine information

Please see the engine Operator's Manual for additional information about servicing the engine.

The manual also has specific information about specifications, tune-up parts, engine warranty, emission compliance, etc.

TROUBLESHOOTING

Troubleshooting schedule



WARNING! Most accidents involving machines occur during trouble shooting, service and maintenance as staff have to locate themselves within the machine's risk area. Prevent accidents by being alert and by planning and preparing the work.

The engine should be switched off during operations described in this chapter unless otherwise stated.

Saw is spalling and raveling cut	Check to see if the diamond blade is worn out, glazed, warped or damaged.
	Ensure skid plate moves freely up and down the entire shaft length without contacting the diamond blade.
	Check skid plate for excessive wear or gap around the diamond blade.
	Check bottom of skid plate for metal burrs or irregularities.
	Ensure skid plate is not twisted or bent.
	Check lexan covers for free movement up and down.
	Ensure there is spring down pressure at each end of the skid plate.
	Do not twist or move the saw sideways while cutting. Make gradual changes in pressure on the handlebar to control the saw in the cut.
	Check that the engine is running properly and at full throttle.
	Check belt and belt idler for proper tension.
	Ensure the diamond blade is properly mounted and secured with clean flanges.
	Ensure that the diamond blade is the correct specification for your area.
	Ensure the slab is in clean with no debris that could raise the skid plate or saw while cutting.
	Use Tomahawk Power joint protectors at all cut intersections.
	Clean excess concrete debris from the blade block assembly.
Check that the scrapers in the blade block are not bent or binding.	
Ensure that the blade block shafts are not bent or damaged.	
Saw pulls to one side while sawing	Check that the front guide is properly aligned with the center of the diamond blade.
	Check to see if the diamond blade is worn out, glazed, warped or damaged.
	Do not twist or move the saw sideways while cutting. Make gradual changes in pressure on the handlebar to control the saw in the cut.
	Ensure that all wheels rolls freely and smoothly.
	Do not force the saw. Allow the diamond blade to cut at its own rate of speed.
	Check the skid plate for damage or burrs.
Engine does not start	Check if there is fuel in the tank and it is the correct fuel. Make sure there is no water in the fuel.
	Check if the fuel valve is turned to the 'on' position.
	Check if the ON/OFF switch is in the 'ON' position.
	Check that the spark plug wire is connected to the spark plug.
	Engine is flooded. Adjust the choke per the engine owner's manual.
	Check the choke is in the 'ON' position for cold starts. Adjust the choke per the engine owner's manual.
	Oil level is too low. Engine is equipped with an oil alert system that will not let the engine start unless the engine oil level is within the correct range.
	Check that air cleaner is not dirty or plugged.
Check that the blade shaft rotates freely and no concrete has built up in the blade block.	
Engine runs rough, back fires or can not reach full speed.	Check if there is fuel in the tank and it is the correct fuel. Make sure there is no water in the fuel.
	Oil level is too low. Engine is equipped with an oil alert system that will not let the engine start unless the engine oil level is within the correct range.
	Check that air cleaner is not dirty or plugged.
	Check that spark plug is clean and properly gapped.
	Check that throttle lever is properly set.
	Check the choke is in the 'ON' position for cold starts. Adjust the choke per the engine owner's manual.

TECHNICAL DATA

Technical data

Engine

Model	Subaru Robin EX 13
Type	Air cooled, 4-cycle, single slant cylinder, overhead camshaft, gasoline engine.
Emissions	Complies with EPA Phase 2 and CARB Tier II USA regulations
Max. engine output (see note 1)	4,3hp@4000rpm (3,2kW@4000rpm)
Fuel tank volume, l (gal)	2,7 (0.7)
Air cleaner	Cyclonic type (Dry type dual element with pre-cleaner)
Cooling	Air cooled with internal and external cooling fins.
Spark plug	NGK BR-6HS (CHAMPION RL86C)
Oil system	Oil alert system with auto shut down sensor.
Oil tank volume, l (quarts)	0,6 (0.6)
Oil type	4-stroke automotive detergent oil of API service class SE or higher grade.

Note 1: As specified by engine manufacturer. The power rating of the engines indicated is the average net power output (at specified rpm) of a typical production engine for the engine model measured to ISO3046. Mass production engines may differ from this value. Actual power output for the engine installed in the final machine will depend on the operating speed, environmental conditions and other variables.

Viscosity - oil

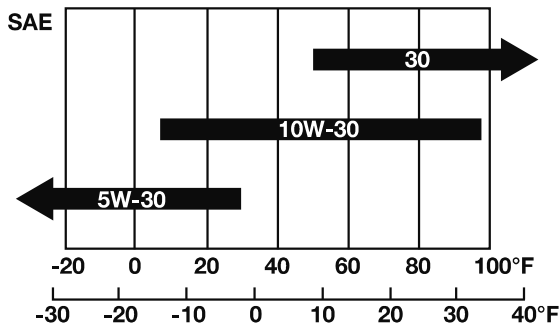

Weight and Dimensions

Weight without fuel, kg (lbs)	38 (84)
Weight with fuel, kg (lbs)	41 (91)
Length (handle folded in), mm (inch)	864 (34)
Width, mm (inch)	483 (19)
Height, mm (inch)	533 (21)

Blade

Blade type	Excel blades, dry cut with tri-arbor
Material	Green concrete only
Blade size - max, mm (inches)	152 (6)
Maximum depth of cut, mm (inch)	30 (1 3/16)
Cutting distance from wall, mm (inch)	76 (3)
Blade rotation	Counter clockwise, upcutting
Blade shaft speed, rpm	4450 (Average 3,800)
Blade depth control	Manual

TECHNICAL DATA

Average cutting rate

Estimate only. Speed will vary with job conditions and concrete mixes.

Soft aggregates, m/min (ft/min)	3,7 (12)
Medium aggregates, m/min (ft/min)	2,4 (8)
Hard aggregates, m/min (ft/min)	1,2 (4)

Noise emissions (see note 1)	
Sound power level, measured dB (A)	97
Sound power level, guaranteed L _{WA} dB (A)	99
Sound levels (see note 2)	
Equivalent sound pressure level at the operator's ear, dB(A)	83
Vibration levels, a_{hv} (see note 3)	
Right handle, m/s ²	5,0
Left handle, m/s ²	4,4